

PWA Shown

Roll over wash unit GENIUS C160		2300	2400	2500	2600	2700	2800	2900	3150
Passage height DFH		2300	2400	2500	2600	2700	2800	2900	3150
L Machine height (with horizontal splash protection + 50mm)		3050	3150	3250	3350	3450	3550	3650	3950
V Clear hall height, min.		3100	3200	3300	3400	3500	3600	3700	3950
Passage width DFB		2400			2550			2700	
Distance wheel guiding pipes ARF		2050			2100			2100	
M Machine width max.									
- without splash protection		3520			3670			3820	
- with splash protection		3720			3870			4020	
- with splash protection and articulated brush for DFH 2300		4045			4195			4345	
- with splash protection and articulated brush for DFH 2400		4075			4225			4375	
- with splash protection and articulated brush for DFH 2500		4105			4255			4405	
- with splash protection and articulated brush for DFH 2600		4135			4285			4435	
- with splash protection and articulated brush for DFH 2700		4165			4315			4465	
- with splash protection and articulated brush for DFH 2800		4195			4345			4495	
Track widths of track		2500			-			-	
Standard		2700			2700			2800	
		2800			2800			2800	
		2900			2900			2900	
		3126			3126			3126	

TE	Connection height E-chain	2300	2400	2500	2600	2700	2800	2900	3150
Z	Safety distance 500 mm								
Z2	Safety distance without emergency-stop device 500 mm								
	Safety distance with emergency-stop device 300 mm								

Legend for supply connections and lines - installed by customer

Pos.	Designation	Specification
E100	Electric connection of PWA inkl. supply pump up to max. 8,0 kW; supply pump up to max. 12,0 kW; supply pump up to max. 16,0 kW; supply pump up to max. 20,0 kW; supply pump up to max. 24,0 kW	400 V, 3/N/PE, 50 Hz, cable with 2 m protrusion 16,0 kW, 32 A 19,5 kW, 36 A 22,0 kW, 40 A 24,0 kW, 48 A
E601	Electric connection of switchboard plant FONTIS-S	3,5 kW, 400 V, 3/N/PE, 50 Hz, 7 A, cable with 2 m protrusion
FW100	Fresh water connection from the water network	Connection DIN EN 10226-1, Rp 1", inner thread, lockable, flow pressure 4 bar, delivery rate 100l/min.
FW101	Fresh water connection from the installations room into the wash hall	Connection DIN EN 10226-1, Rp 1", inner thread, lockable, flow pressure 4 bar, delivery rate 100l/min.
FW102	Fresh water connection wash hall	Connection DIN EN 10226-1, Rp 1", inner thread, flow pressure 4 bar, delivery rate 100l/min.
WF100	Fresh water pressure line	Flow pressure 4 bar, delivery rate 100l/min.
RW101	Recycled water connection from the installations room into the wash hall	Connection DIN EN 10226-1, Rp 1", inner thread, flow pressure 4 bar, delivery rate 100l/min.
RW102	Recycled water connection wash hall	Connection DIN EN 10226-1, Rp 1", inner thread, flow pressure 4 bar, delivery rate 100l/min.
WR100	Recycled water pressure line	Flow pressure 4 bar, delivery rate 100l/min.
A100	Compressed air connection installations room	Connection DIN EN 10226-1, Rp 1/2", inner thread, lockable, flow pressure 6 bar, delivery rate (of a piston compressor): 300 l/min. - plant with anti-frost / water emptying 200 l/min. - plant without anti-frost / water emptying
A111	Compressed air connection from the installations room into the wash hall	Connection DIN EN 10226-1, Rp 1/2", inner thread, lockable, flow pressure 6 bar, delivery rate 300 l/min.
A112	Compressed air connection wash hall	Connection DIN EN 10226-1, Rp 1/2", inner thread, flow pressure 6 bar, delivery rate 300 l/min.
A100	Compressed air line	Flow pressure 6 bar, delivery rate 300 l/min.

Legend for underground pipe an empty conduits - installed by customer

Pos.	Designation	Specification
P101	Outlet pipe FONTIS-S - BWA	DN 100, with gradient to the sewerage system
P102	Outlet pipe FONTIS-S - backwash	DN 100, with gradient to the UBW or sludge trap
P103	Empty conduit FONTIS-S - flocculant dosing	DN 50, with pulling wire and gradient to the UBW or sludge trap
P104	Empty conduit UBW	DN 100, with pulling wire and gradient to the UBW
P105	Pressure line FONTIS-S - wastewater, (with use of CHRIST-BIOCLEAR twin version)	DN 50 (HDPE)-pipe 63x5,8 mm, PN6, DIN 8074/8075), connection: DIN EN 10226-1, Rp 2", inner thread, both on sides, gradient to discharge tank, max. length 25 m, geodetic height 3 m
P106	Empty conduit FONTIS-S supply line for discharge tank	KG 160, DIN 19534 (water-bearing), with pulling wire gradient to the discharge tank
P107	Outlet pipe installations room	DN 100, with gradient to the sludge trap
C101	Empty conduit C-CAT data cable, to the cash office	DN 50, with pulling wire to the cash office (request data cable for installation by the customer from CHRIST)

General pointers:

- This plan is a general one and cannot be used as implementation plan.
- This plan is a reference for the architect / planner.
- Inform the OTTO CHRIST AG about any deviation of the customer provided performances.
- Specified dimensions in mm.
- The specified dimensions concern the prefabrication.
- The wash hall and the installations room shall be illuminated according to the regulations.
- The wash hall and the installations room shall be sufficiently aerated and ventilated.
- The sites of the wash systems and the technology must be frost proof.
- The floor of the wash halls, wash bays and installations rooms shall be liquid-light and skid-resistant.
- Make sure that the elements / device placed in the wash hall and the installations room are sufficiently protected against corrosion.
- The walls, paints, wall and floor tiles shall be resistant against the chemicals that will be used.
- All lines and connections described in the legend must be provided by the customer and installed according to local regulations.
- The outlet pipes, empty conduits and lines installed indoor and outdoor must be frost resistant.
- Wash halls in light construction, a crossarm is required over the complete hall length to accommodate the E-chain.
- In the work and traffic zone of the wash system, a safety distance of min. 500 mm shall be available between the wash system and the fixed parts of the surrounding, up to a height of 2000 mm over the stand area of staff. If the safety gap cannot be maintained, automatic safety devices are required.
- In the work area of the wash system (= clear hall length, width and height) no disturbing contours are permitted due to parts provided by the customer.
- The use of a water preparation unit, the model of the separator system and the waste water inlet line must be in accordance with local regulations and are subject to approval.
- The recirculation and sewage pre-treatment of sewage water from the mechanical vehicle cleaning for cleaning into the public drainage system in accordance with annex 4.9 of the wastewater decree (AbwV) must either take place via the sludge trap 5000 l, the discharge tank 5000 l and separator of class I in accordance with DIN EN 858-1, DIN EN 858-2 and DIN 1999-100.
- Empty conduits must be closed by the customer after installation by CHRIST.
- It is up to the customer to take protective measures as required by the public power supply company for the electrical cables. If a leakage current protection device is used, the electric supply line ET type B (sensitive to oil types of current) with min. 300 mA is the only one approved. Separate protective measures should be taken by the customer for the wash technique.
- The CHRIST door control shall be connected to the one provided by the customer by the door manufacturer or an electrician ordered by the customer. The surveillance of the doors shall be ensured by means of the door control of the door manufacturer.
- The electric supply lines provided by the customer must be connected to the CHRIST switchboard plant in accordance with the connection provisions specified by the local power supply company.
- Subject to technical modifications.

OTTO CHRIST AG WASH SYSTEMS 87882 MICHINGEN POSTFACH 3254 · TELEFON 08331857-0		© OTTO CHRIST AG 2016 · SCHUTZVERMERK 10 8036 BEAHTEN	Maßstab 1 : 50 A1
05 UBW 101 · Text 11.12.16 Brehm 04 Text Anp. Nel-Hart 21.10.16 Brehm 03 Textanpassung DFH 11.10.16 Brehm 02 Text Ergänz. DFH/DFB/Spr 03.08.16 Rainel 01 Pl 300 mA 14.04.15 Brehm		Datum Name 08.11.12 Brehm Bearb. Name Gepr.	INSTALLATION PLAN C160 GENIUS 8421160-EN REV 05 Blatt 1

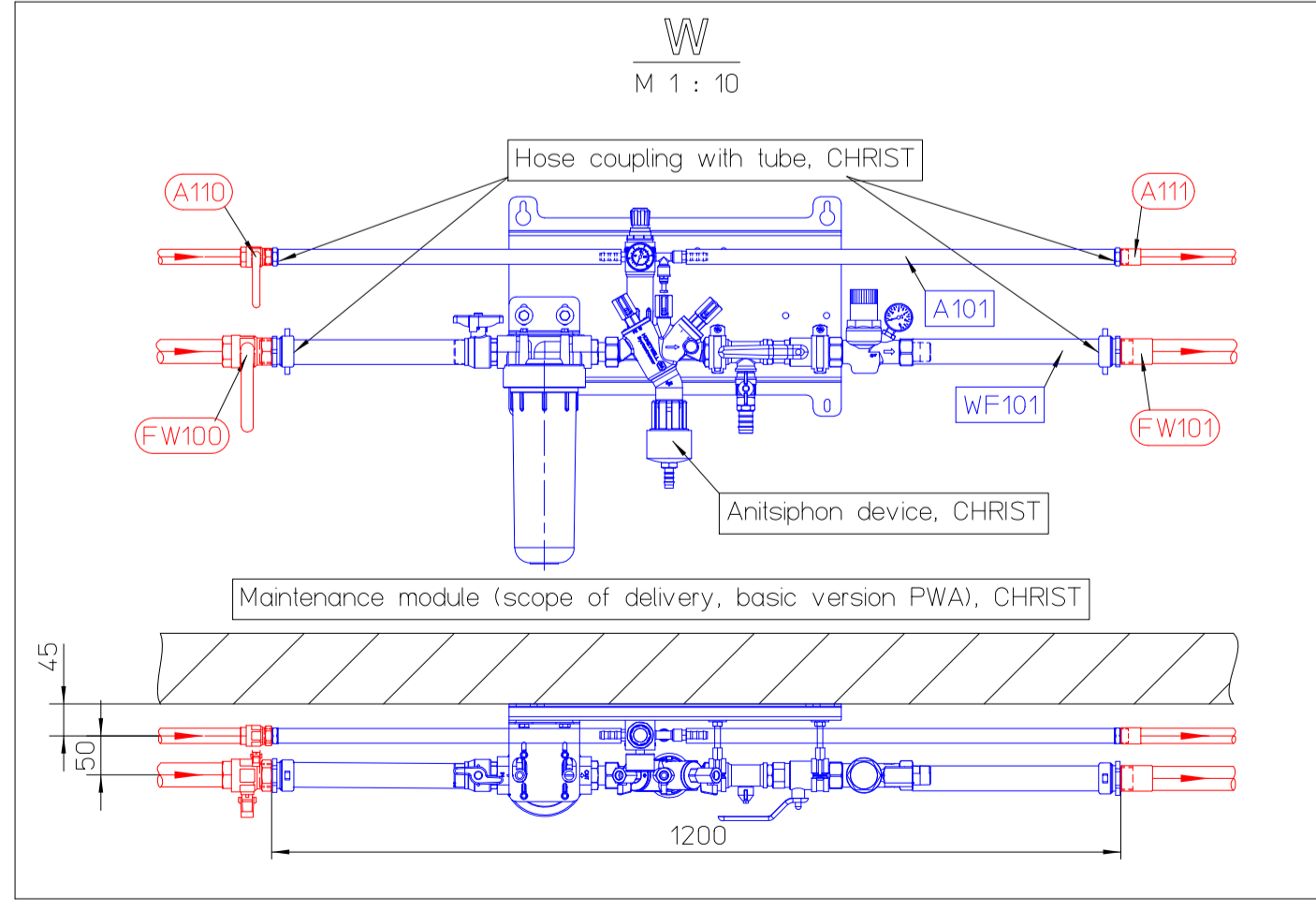
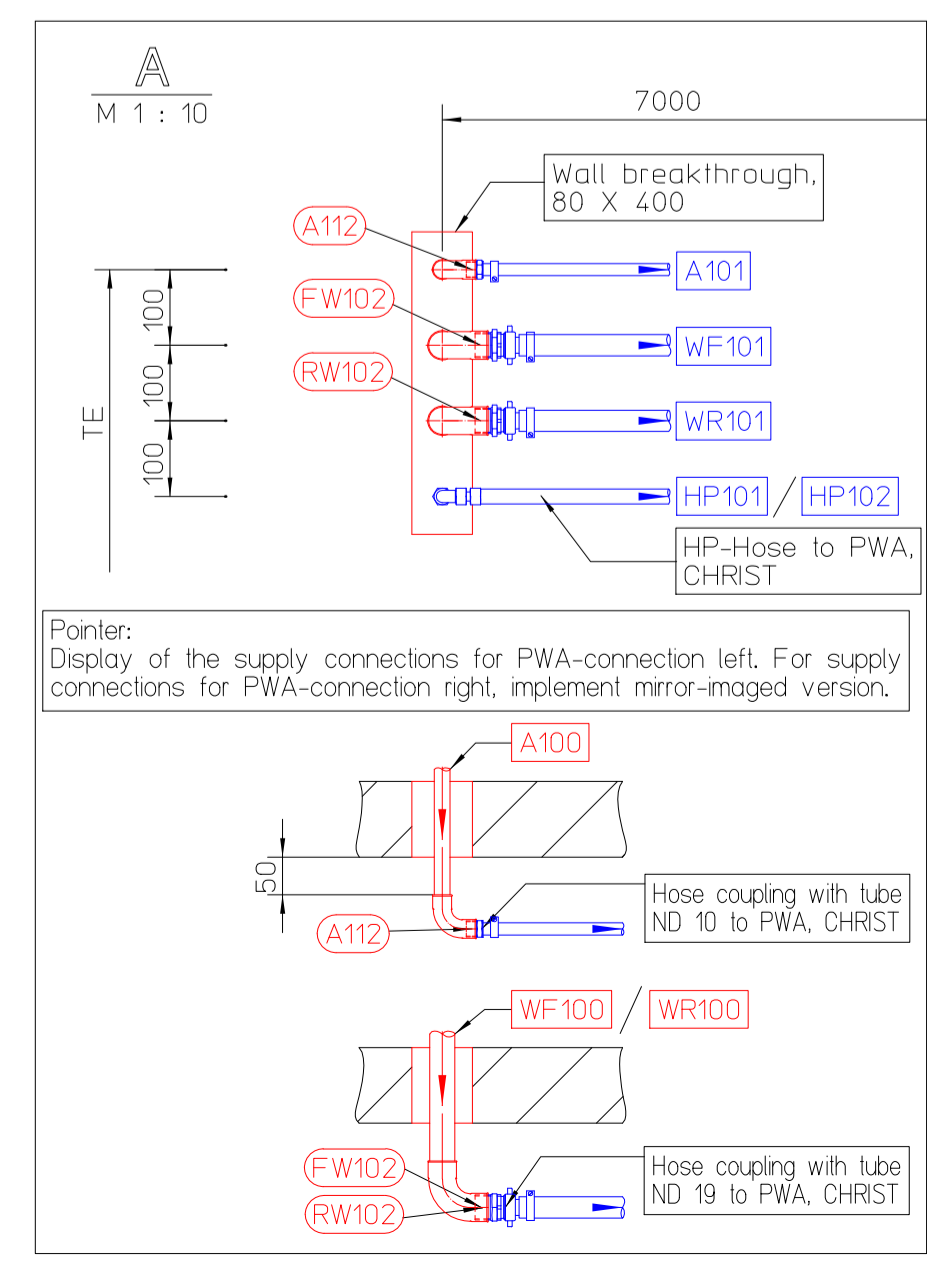
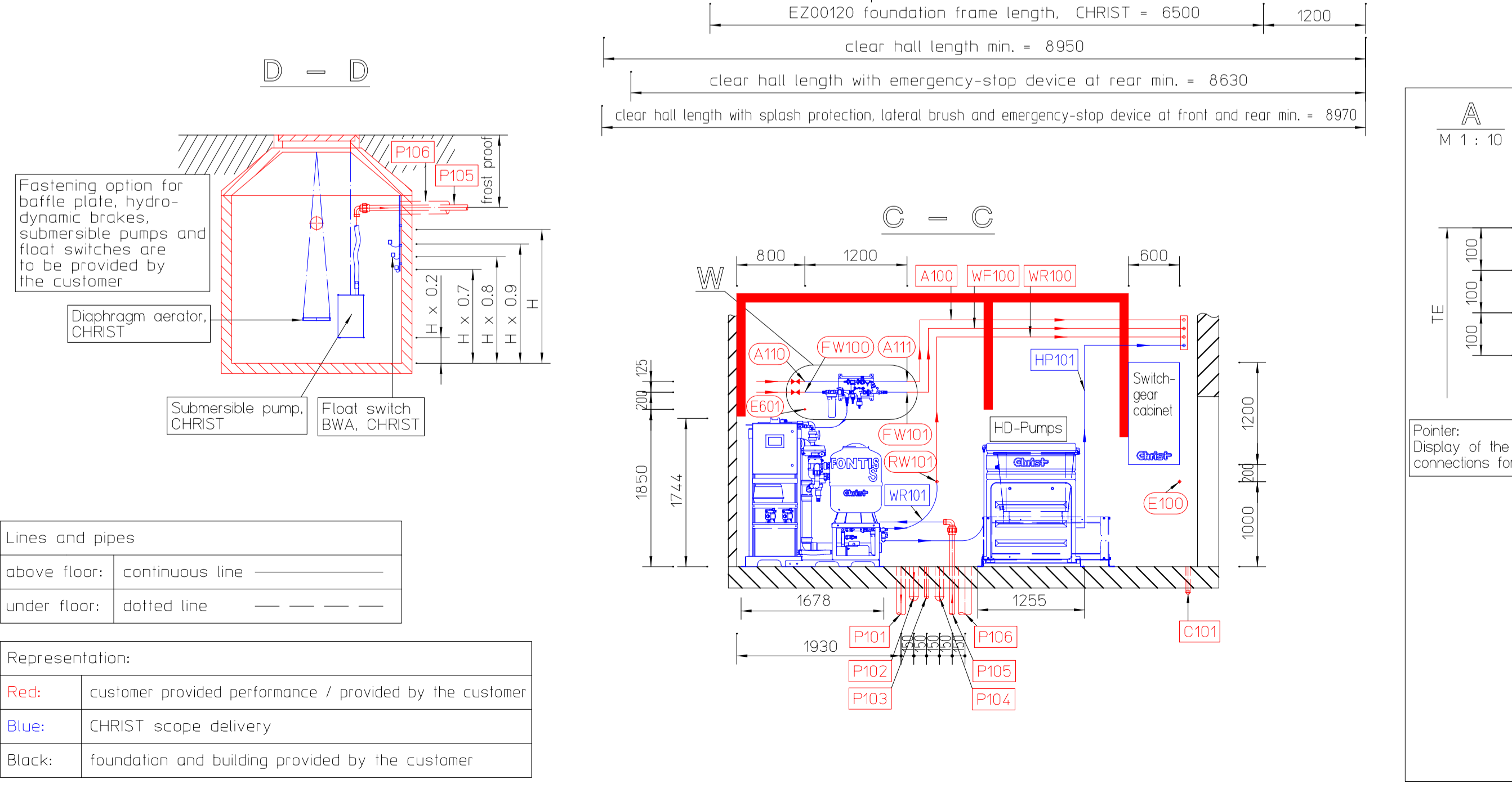
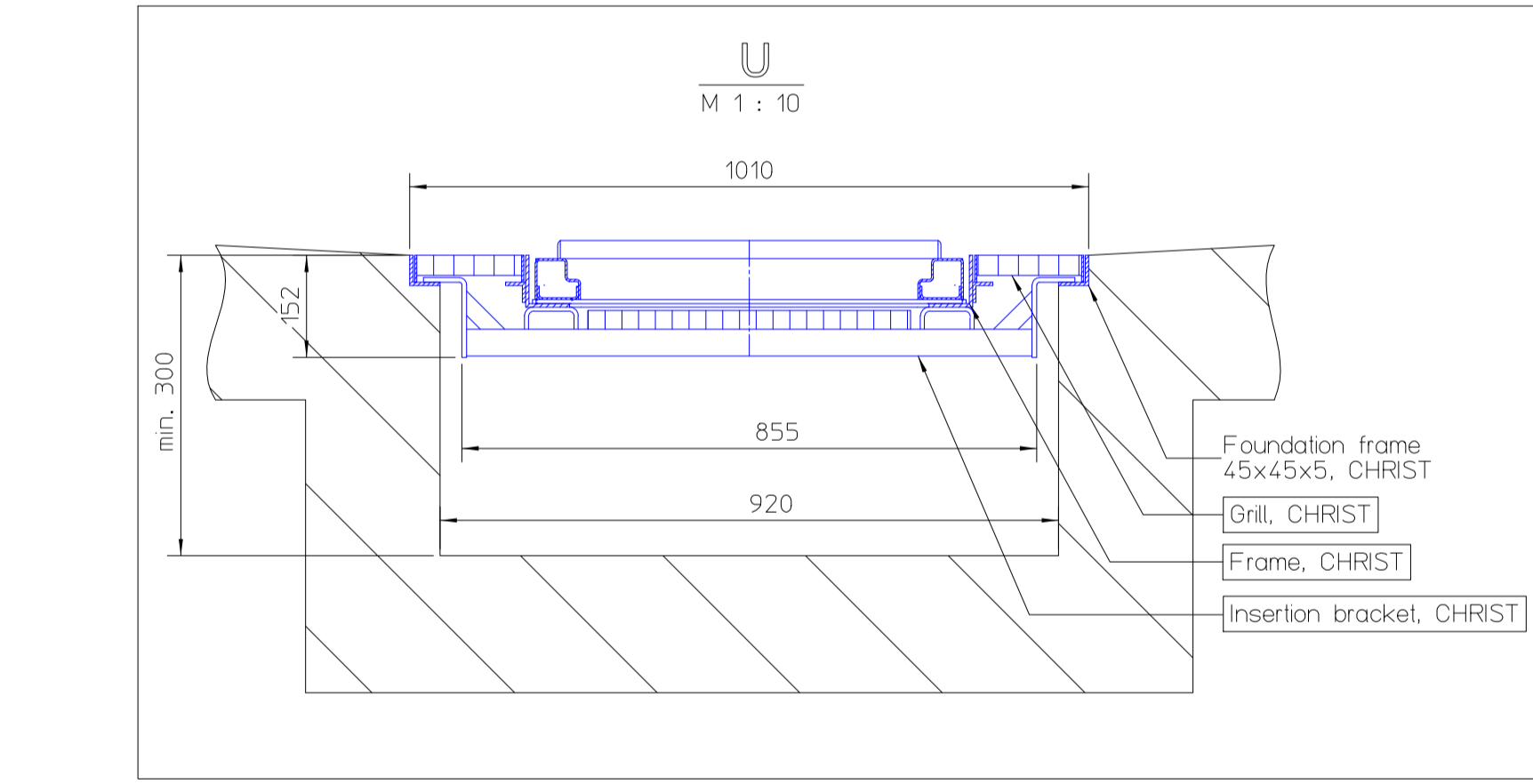
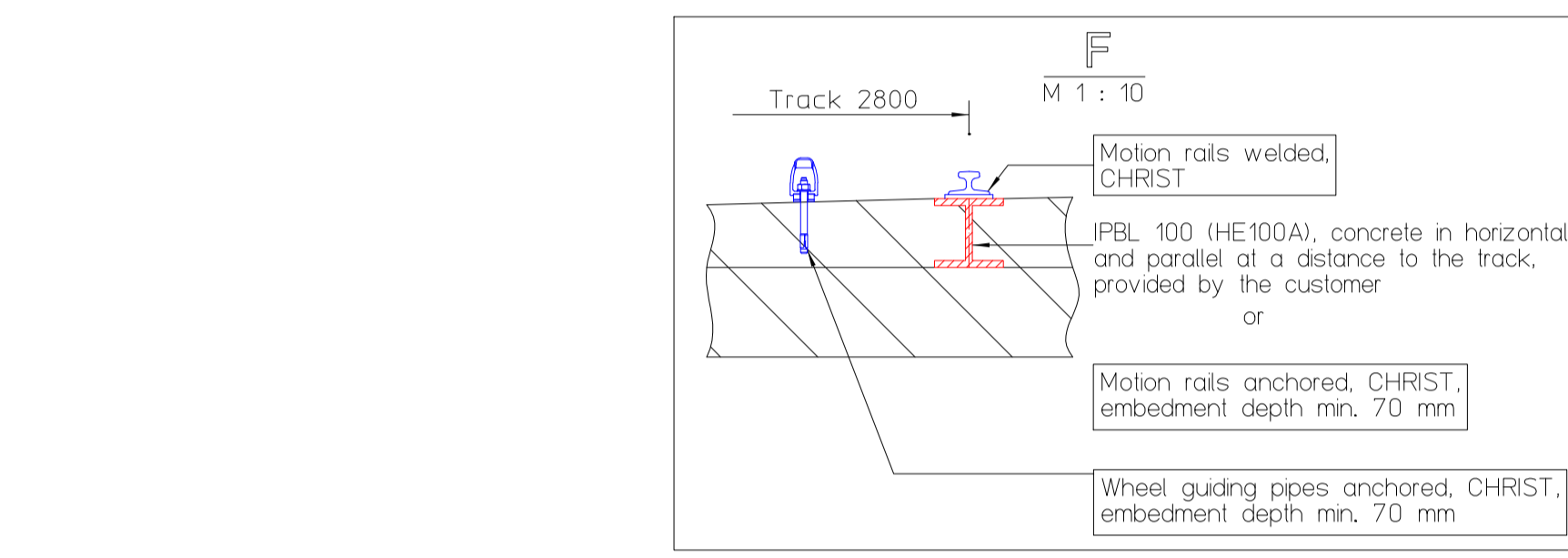
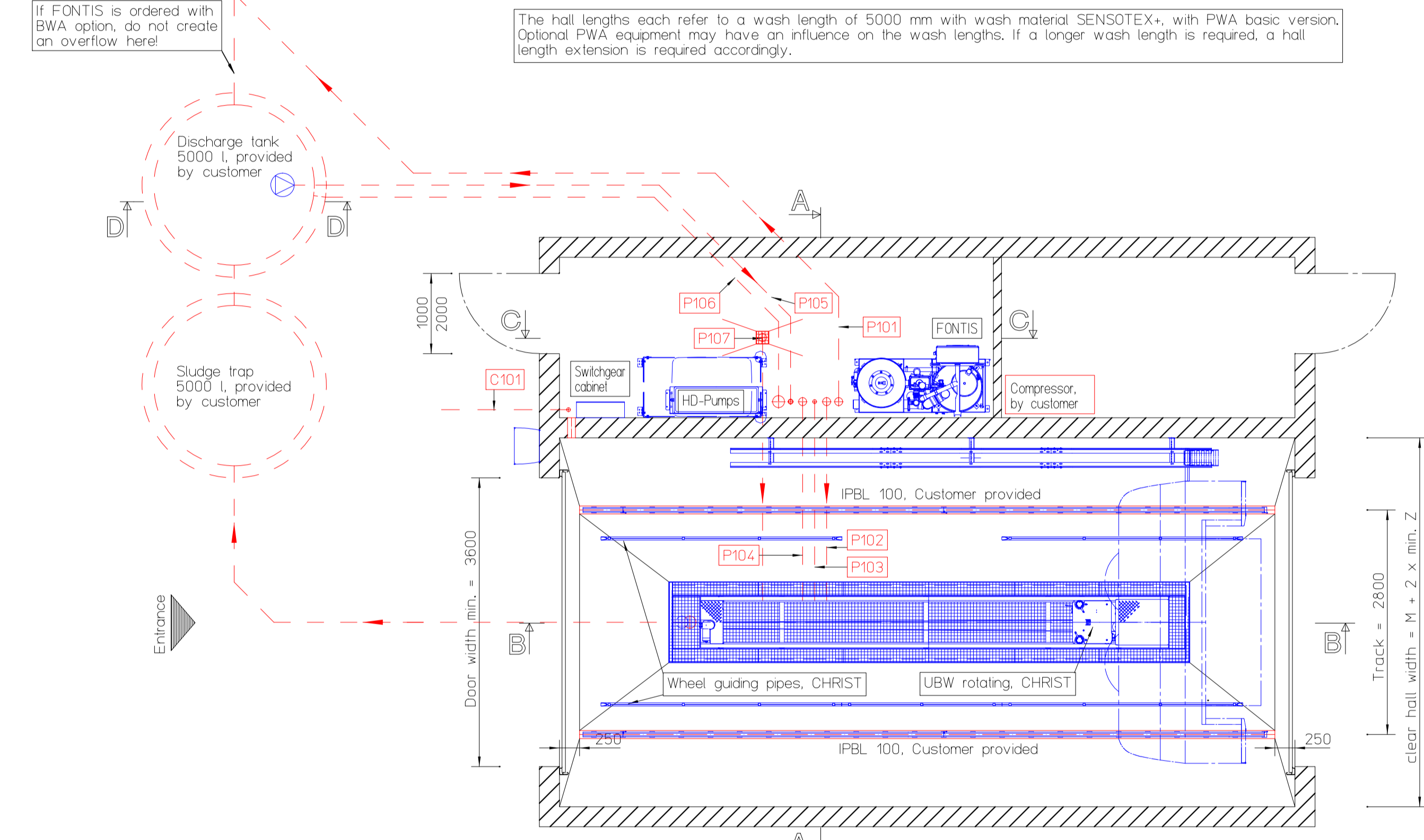
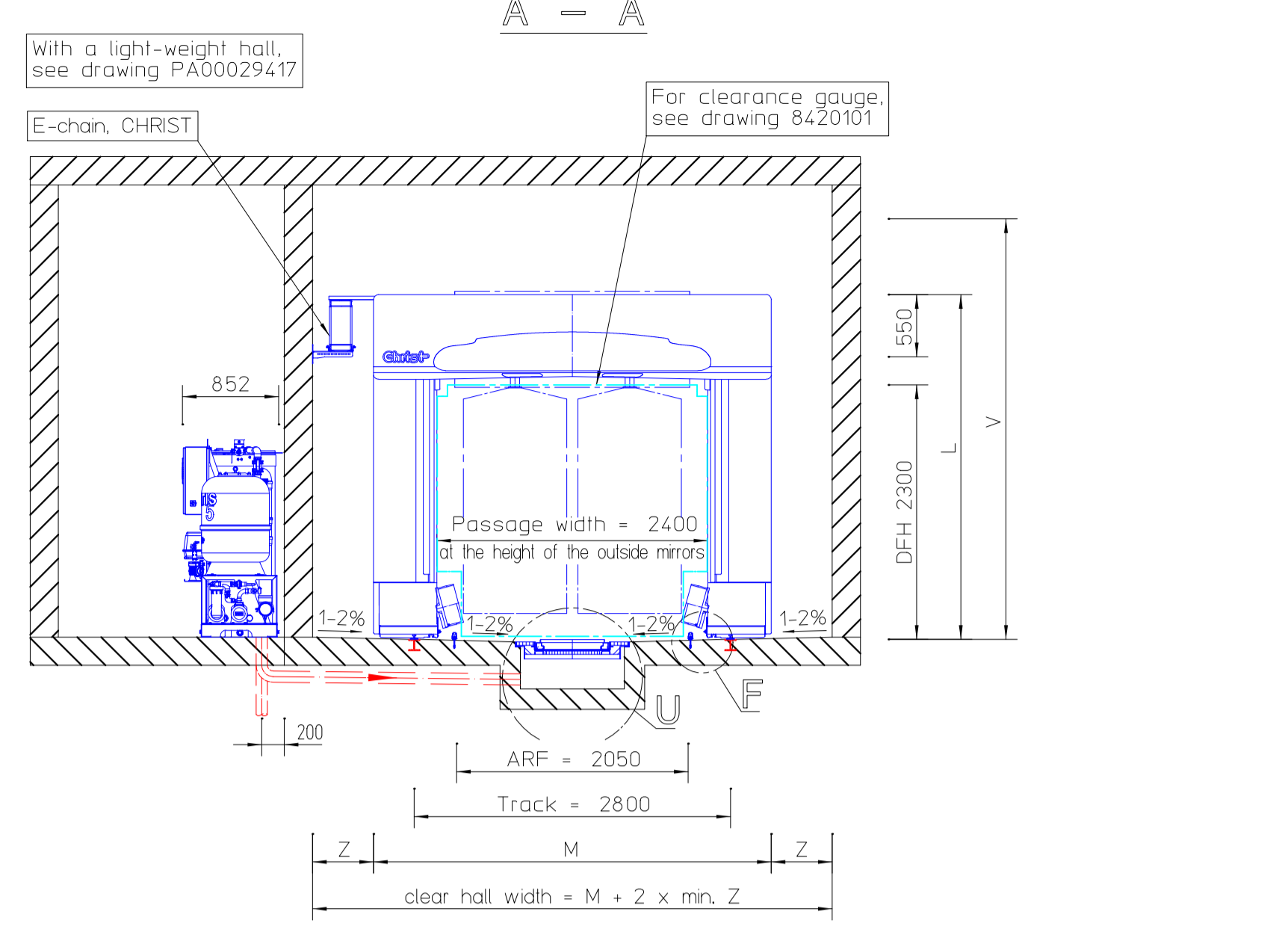
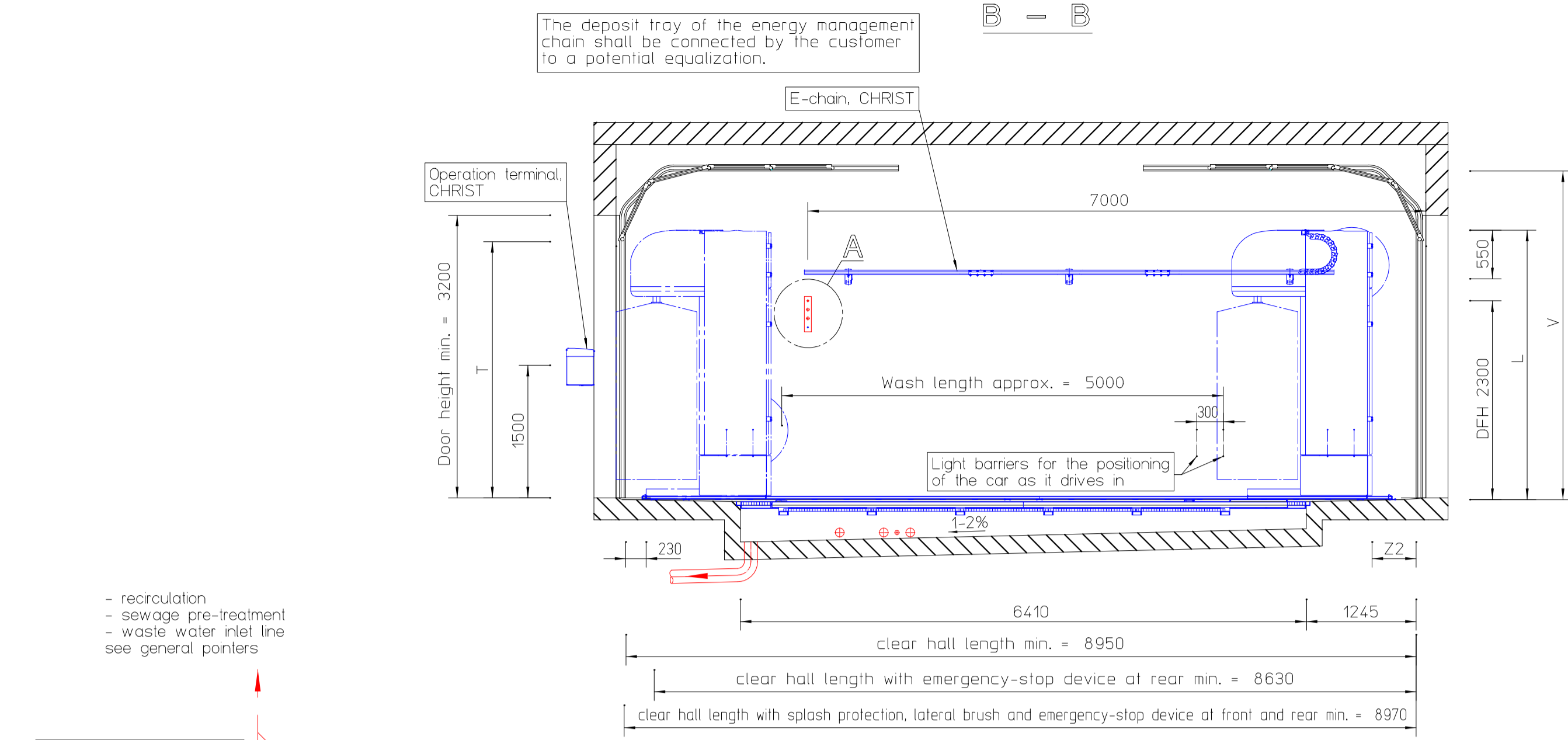

Abbreviations:

PWA	roll over wash unit
UBW	under-chassis wash device
BWA	recycled water ejection
E-chain	energy management chain
ARF	distance, wheel guiding pipes
HD	high-pressure

Legend for the lines: by Christ

Pos.	Designation
WF101	pressure line for fresh water 1
WR101	pressure line for recycled water 1
HP101	pressure line for high-pressure 1
HP102	pressure line for high-pressure 2
A101	compressed air line

Lines and pipes

above floor:	continuous line
under floor:	dotted line

Representation:

Red:	customer provided performance / provided by the customer
Blue:	CHRIST scope delivery
Black:	foundation and building provided by the customer